

## PRODUCT OVERVIEW IPP DELTAFLEX® Flange Engineering

Improved Piping Products, Inc. (IPP) has patented the second generation convoluted pipe back-up rings and markets that technology under the registered trade name of IPP Deltaflex® flanges. The unique design technology significantly reduces the weight of a flange without reducing its pressure performance.

### PRODUCT OVERVIEW IPP Deltaflex® Flange Engineering

The finite element analysis (FEA) tool utilized by IPP is ANSYS 5.3. Using these tools, the company has examined the stress levels inside standard piping flange joints and in the adjacent pipe walls. From this analysis, IPP has confirmed that nationally recognized pipe flanges are very conservatively stressed while the adjacent pipe walls often exceed allowable code stress values, in many cases approaching the yield point of the piping material.

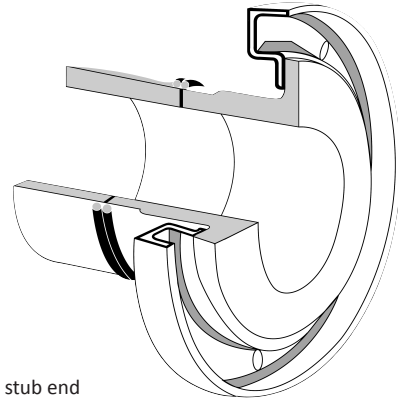

IPP Deltaflex® flange on stub end

In response to this IPP Deltaflex® flanges are designed to allowable code stress levels with a safety factor of 2. Even with this generous safety factor IPP Deltaflex® flanges are much lower stressed than the abutting pipe wall material. Therefore a properly selected IPP Deltaflex® flange is not the weakest link in a pipe system when the adjacent pipe wall is closely examined.

IPP Deltaflex® flanges are safe, functional structures with an attractive economic dimension. They conserve material and energy resources from manufacture to point of installation. The lower weight translates into several benefits:

- Lower cost of raw material and energy
- Reduced transport costs
- Ease of handling and installation

The IPP Deltaflex® flanges can be substituted for a conventional pipe flange as called out in DIN, ANSI B16.5, B16.47 and AWWA C207. Its unique cross section can save up to 40% of the weight of one of these national pipe standard flanges. Some installation practices have thinned the standard flanges for economic reasons. In these instances using IPP Deltaflex® flanges design principles can reduce the critically high stress levels to a stated safety factor. This performance is achieved by using IPP Deltaflex® flange engineering to increase the section modulus of the flange without increasing its weight. See figure 1 & 2, comparison of IPP Deltaflex® flange and conventional steel flange.

IPP has installed literally millions of its patented convoluted flanges in the entire spectrum of code controlled commercial and industrial pipe systems. The design technology has consistently been the specification choice of world renowned piping engineers. The IPP Deltaflex® flange truly satisfies the claim of being a modern, high performance pipe flange. Pound for pound there exists no other pipe flange that can safely carry structural loads as efficiently as an IPP Deltaflex® flange.

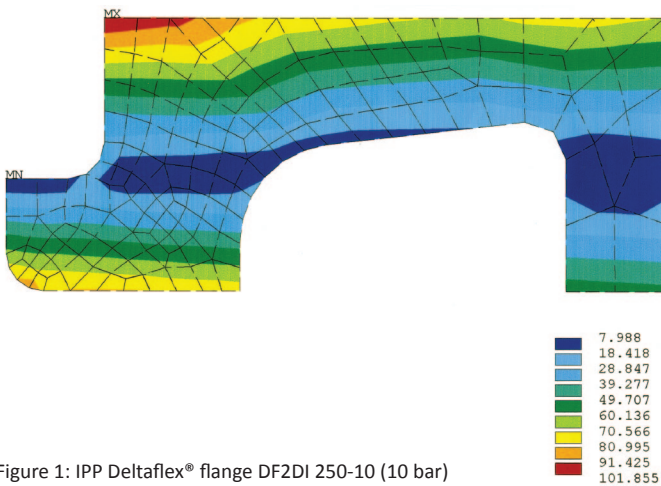

Figure 1: IPP Deltaflex® flange DF2DI 250-10 (10 bar)

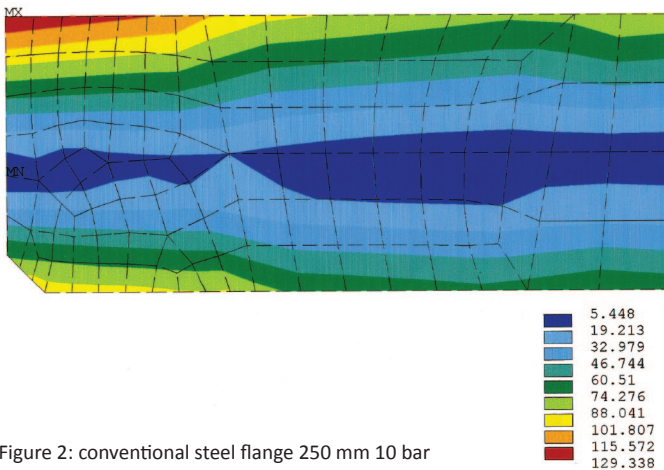
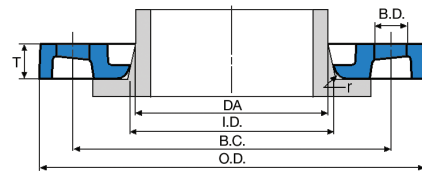
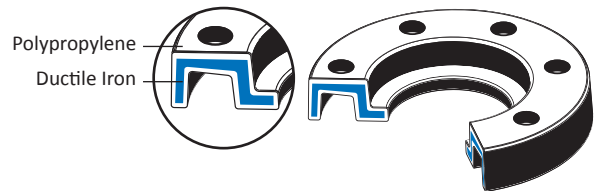

Figure 2: conventional steel flange 250 mm 10 bar

## PPDA-Flanges (for buttwelding)

### PP/Steel – ductile iron GGG 40 insert with 30% glasfibre reinforced polypropylene encapsulation

<b>Description</b>	Ductile iron flange with 30% glasfibre reinforced polypropylene encapsulation. A high corrosion resistant flange for use with PE, PP and PVDF stub ends.
<b>Utilization</b>	For buttwelding systems, sizes DA 20 – DA 75 can be used for socket welding systems also. A perfect choice, where high corrosion resistance is required.
<b>Connecting Dimensions</b>	Drilled to ISO 7005, EN 1092, DIN 2501 PN 10/16 (DA 20 – 180: PN10/16; > DA 180 PN 10)
<b>Materials</b>	Ductile iron (GGG 40, DIN 1693), encapsulated by 30% glasfibre reinforced polypropylene (black).
<b>Info</b>	Max. operating pressure: connecting dimensions PN and max. operating pressure in bar are not directly linked. For example: a PPDA Flange in size DA 225-10 is drilled in acc. to DIN 2501 / EN 1092 <b>PN 10</b> , but max. operating pressure is <b>16 bar</b> .



IPP recommends use of washers (below screw head and nut)

DA	DN	Code	Outside Dia. O.D.	Inside Dia. I.D.	Flange Thickness T	Bolt Circle B.C.	Bolt Hole B.D.	Bolt Count N	Bolt Size M	Radius r	Operating Pressure max. [bar]	Weight kg/pc.
20	15	PPDA 20-10/16	106	28	18	65	14	4	M12	3	16	0,35
25	20	PPDA 25-10/16	118	34	18	75	14	4	M12	3	16	0,45
32	25	PPDA 32-10/16	122	42	17	85	14	4	M12	3	16	0,50
40	32	PPDA 40-10/16	142	51	17	100	18	4	M16	3	16	0,55
50	40	PPDA 50-10/16	156	62	19	110	18	4	M16	3	16	0,75
63	50	PPDA 63-10/16	171	78	20	125	18	4	M16	3	16	0,90
75	65	PPDA 75-10/16	191	92	21	145	18	4	M16	3	16	1,10
90	80	PPDA 90-10/16	206	108	21	160	18	8	M16	3	16	1,30
110	100	PPDA 110-10/16	226	128	22	180	18	8	M16	3	16	1,40
125	100	PPDA 125-10/16	226	135	23	180	18	8	M16	3	16	1,35
140	125	PPDA 140-10/16	261	158	25	210	18	8	M16	3	16	1,80
160	150	PPDA 160-10/16	296	178	28	240	22	8	M20	3	16	2,40
180	150	PPDA 180-10/16	296	188	27	240	22	8	M20	4	16	2,25
200	200	PPDA 200-10	350	235	32	295	22	8	M20	4	16	3,45
225	200	PPDA 225-10	350	238	31	295	22	8	M20	4	16	3,10
250	250	PPDA 250-10	412	288	36	350	22	12	M20	4	16	5,10
280	250	PPDA 280-10	412	294	35	350	22	12	M20	4	16	4,80
315	300	PPDA 315-10	462	338	42	400	22	12	M20	4	16	7,15
355	350	PPDA 355-10	525	376	52	460	22	16	M20	6	16	11,5
400	400	PPDA 400-10	586	430	56	515	26	16	M24	6	16	14,7
450	500	PPDA 450-10	690	514	54,5	620	27	20	M24	6	10	19,0
500	500	PPDA 500-10	690	530	55	620	27	20	M24	6	10	19,0
560	600	PPDA 560-10	804	615	62	725	30	20	M27	6	10	30,0
630	600	PPDA 630-10	804	642	62	725	30	20	M27	6	10	27,7
710	700	PPDA 710-10	912	740	49	840	30	24	M27	5	6	28,6
800	800	PPDA 800-10	1026	843	58	950	33	24	M30	5	6	39,3
900	900	PPDA 900-10	1129	947	62	1050	33	28	M30	5	6	48,5
1000	1000	PPDA 1000-10	1245	1050	70	1160	36	28	M33	5	6	60,0

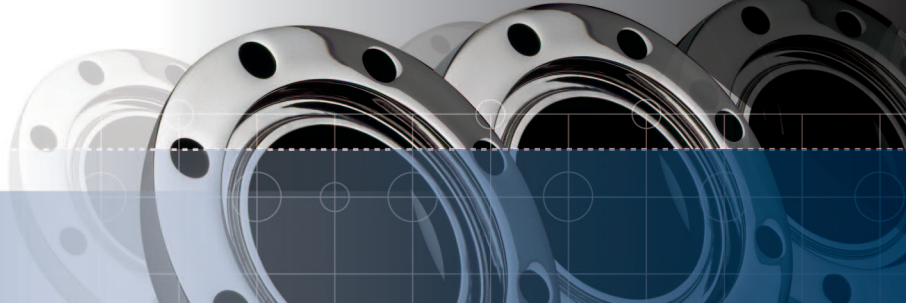

## PPDA-Flanges (for socket welding)

### PP/Steel – ductile iron GGG 40 insert with 30% glasfibre reinforced polypropylene encapsulation

**Description** Ductile iron flange with 30% glasfibre reinforced polypropylene encapsulation. A high corrosion resistant flange for use with PE, PP and PVDF stub ends.

**Utilization** For socket welding systems, sizes DA 20 – DA 75 can be used for butt welding systems also. A perfect choice, where high corrosion resistance is required.

**Connecting Dimensions** Drilled to ISO 7005, EN 1092, DIN 2501 PN 10/16 (DA 20 – 180: PN10/16; > DA 180 PN 10)

**Material** Ductile iron (GGG 40, DIN 1693), encapsulated by 30% glasfibre reinforced polypropylene (black).

**Info** IPP recommends use of washers (below screw head and nut)

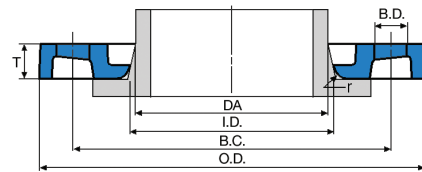
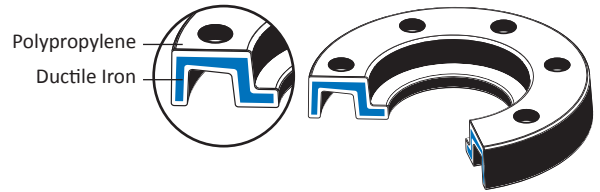

DA	DN	Code	Outside Dia. O.D.	Inside Dia. I.D.	Flange Thickness T	Bolt Circle B.C.	Bolt Hole B.D.	Bolt Count N	Bolt Size M	Radius r	Operating Pressure max. [bar]	Weight kg/pc.
20	15	PPDA 20-10/16	106	28	18	65	14	4	M12	3	16	0,35
25	20	PPDA 25-10/16	118	34	18	75	14	4	M12	3	16	0,45
32	25	PPDA 32-10/16	122	42	17	85	14	4	M12	3	16	0,50
40	32	PPDA 40-10/16	142	51	17	100	18	4	M16	3	16	0,55
50	40	PPDA 50-10/16	156	62	19	110	18	4	M16	3	16	0,75
63	50	PPDA 63-10/16	171	78	20	125	18	4	M16	3	16	0,90
75	65	PPDA 75-10/16	191	92	21	145	18	4	M16	3	16	1,10
90	80	PPDA 90-10/16 sw	206	110	21	160	18	8	M16	3	16	1,10
110	100	PPDA 110-10/16 sw	226	133	22	180	18	8	M16	3	16	1,40
140	125	PPDA 140-10/16 sw	261	167	26	210	18	8	M16	3	16	1,70
160	150	PPDA 160-10/16 sw	296	190	28	240	22	8	M20	3	16	2,30
225	200	PPDA 225-10 sw	350	250	23	295	22	8	M20	3	10	2,40
250	250	PPDA 250-10 sw	403	277	35	350	22	12	M20	4	10	4,90
280	250	PPDA 280-10 sw	403	310	31	350	22	12	M20	4	10	3,65
315	300	PPDA 315-10 sw	458	348	37	400	22	12	M20	4	10	5,95

## PPDI-Flanges (Flange I.D. in acc. to DIN/EN, drilled ANSI)

### PP/Steel – ductile iron GGG 40 insert with 30% glasfibre reinforced polypropylene encapsulation

<b>Description</b>	Ductile iron flange with 30% glasfibre reinforced polypropylene encapsulation. A high corrosion resistant flange for use with PE, PP and PVDF stub ends.
<b>Utilization</b>	For butt welding systems, size DA 63 can be used for socket welding systems also. A perfect choice, where high corrosion resistance is required.
<b>Connecting Dimensions</b>	Drilled to ANSI B16.5 class 150 series A and AWWA C207
<b>Material</b>	Ductile iron (GGG 40, DIN 1693), encapsulated by 30% glasfibre reinforced polypropylene (black).
<b>Info</b>	Flange I.D. in accordance to DIN/EN, drilled to ANSI B16.5 class 150. I.D. considered for butt welding systems, in size DA 63 for socket welding also.

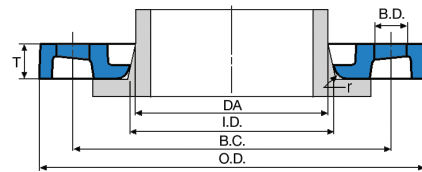
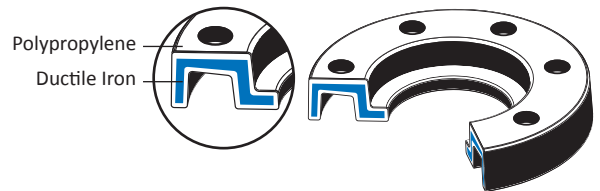

IPP recommends use of washers (below screw head and nut)

DA	DN	Code	Outside Dia. O.D.	Inside Dia. I.D.	Flange Thickness T	Bolt Circle B.C.	Bolt Hole B.D.	Bolt Count N	Bolt Size M	Radius r	Operating Pressure max. [bar]	Weight kg/pc.
63	2"	PPDI 63-2"	164	78	18	121	19	4	M16	4	16	0,80
90	3"	PPDI 90-3"	196	108	19	153	19	4	M16	4	16	1,00
110	4"	PPDI 110-4"	237	128	25	191	19	8	M16	4	16	1,80
160	6"	PPDI 160-6"	297	178	30	242	22	8	M20	4	16	3,20
225	8"	PPDI 225-8"	354	238	34	299	22	8	M20	4	16	5,10
250	10"	PPDI 250-10"	425	288	38	362	26	12	M20	4	16	6,90
315	12"	PPDI 315-12"	497	338	51	432	26	12	M20	6	16	12,8

## DF2DI-Flanges (for butt welding) - PN 10 drilling

**Ductile iron GGG 40 flanges – Epoxy coated (black), available on request in hot dip galvanized finish**

<b>Description</b>	Ductile iron GGG 40 flange, epoxy coated (black). A corrosion resistant flange for use with PE, PP and PVDF stub ends.
<b>Utilization</b>	For butt welding systems, sizes DA 50 – DA 75 can be used for socket welding systems also.
<b>Connecting Dimensions</b>	Drilled to ISO 7005, EN 1092, DIN 2501 PN 10/16 (DA 20 – 180: <b>PN10/16</b> ; DA 200 – DA 1600 mm: <b>PN 10</b> )
<b>Material</b>	Ductile iron (GGG 40, DIN 1693), Epoxy coated (black), available with hot dip galvanized finish on request.
<b>Info</b>	<b>Max. operating pressure:</b> sizes DA 50 – 180 mm: <b>16 bar</b> sizes DA 200 – 630 mm: <b>10 bar</b> sizes DA 710 – 1000 mm: <b>6 bar</b> sizes DA 1200 – 1600 mm: <b>4 bar</b>

IPP recommends use of washers (below screw head and nut)

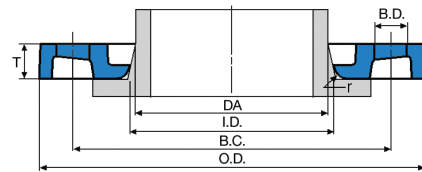
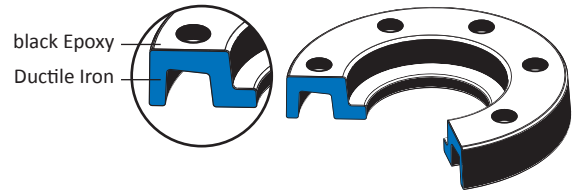

DA	DN	Code	Outside Dia. O.D.	Inside Dia. I.D.	Flange Thickness T	Bolt Circle B.C.	Bolt Hole B.D.	Bolt Count N	Bolt Size M	Radius r	Operating Pressure max. [bar]	Weight kg/pc.
50	40	DF2DI 50-10/16	150	62	16	110	18	4	M16	3	16	1,05
63	50	DF2DI 63-10/16	165	78	16	125	18	4	M16	3	16	1,30
75	65	DF2DI 75-10/16	185	92	16	145	18	4	M16	3	16	1,35
90	80	DF2DI 90-10/16	200	108	19	160	18	8	M16	3	16	1,75
110	100	DF2DI 110-10/16	220	128	19	180	18	8	M16	3	16	1,90
125	100	DF2DI 125-10/16	220	135	19	180	18	8	M16	3	16	1,80
140	125	DF2DI 140-10/16	250	158	19	210	18	8	M16	3	16	2,30
160	150	DF2DI 160-10/16	285	178	19	240	22	8	M20	3	16	2,95
180	150	DF2DI 180-10/16	285	188	19	240	22	8	M20	3	16	2,80
200	200	DF2DI 200-10	340	235	18	295	22	8	M20	3	10	3,75
225	200	DF2DI 225-10	340	238	18	295	22	8	M20	3	10	3,65
250	250	DF2DI 250-10	395	288	22	350	22	12	M20	3	10	6,55
280	250	DF2DI 280-10	395	294	22	350	22	12	M20	3	10	5,50
315	300	DF2DI 315-10	445	338	26	400	22	12	M20	3	10	6,65
355	350	DF2DI 355-10	505	376	30	460	22	16	M20	4	10	11,9
400	400	DF2DI 400-10	565	430	34	515	26	16	M24	4	10	17,4
450	500	DF2DI 450-10	670	517	42	620	26	20	M24	6	10	22,5
500	500	DF2DI 500-10	670	533	38	620	26	20	M24	4	10	23,3
560	600	DF2DI 560-10	785	618	50	725	30	20	M27	7	10	40,0
630	600	DF2DI 630-10	785	645	40	725	30	20	M27	4	10	26,8
710	700	DF2DI 710-10	900	740	45	840	30	24	M27	5	6	38,5
800	800	DF2DI 800-10	1015	843	53	950	33	24	M30	5	6	56,5
900	900	DF2DI 900-10	1115	947	56	1050	33	28	M30	5	6	59,6
1000	1000	DF2DI 1000-10	1230	1050	62	1160	36	28	M33	5	6	75,0
1200	1200	DF2DI 1200-10	1455	1260	68	1380	39	32	M36	6	4	107
1400	1400	DF2DI 1400-10	1675	1441	72	1590	42	36	M39	6	4	143
1600	1600	DF2DI 1600-10	1915	1644	84	1820	48	40	M45	6	4	203

## DF2DI-Flanges (for butt welding) - PN 16 drilling

**Ductile iron GGG 40 flanges – Epoxy coated (black), available on request in hot dip galvanized finish**

**Description** Ductile iron GGG 40 flange, epoxy coated (black). A corrosion resistant flange for use with PE, PP and PVDF stub ends.

**Utilization** For butt welding systems, sizes DA 50 – DA 75 can be used for socket welding systems also.

**Connecting Dimensions** Drilled to ISO 7005, EN 1092, DIN 2501 PN 10/16 (DA 20 – 180: **PN10/16**; DA 200 – DA 630 mm: **PN 10**)

**Material** Ductile iron (GGG 40, DIN 1693), Epoxy coated (black), available with hot dip galvanized finish on request.

**Info** Max. operating pressure: sizes DA 50 – 630 mm: **16 bar**  
 IPP recommends use of washers (below screw head and nut)

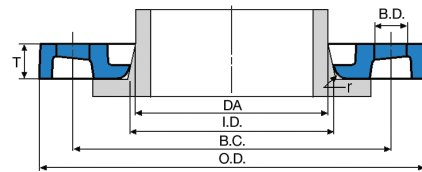
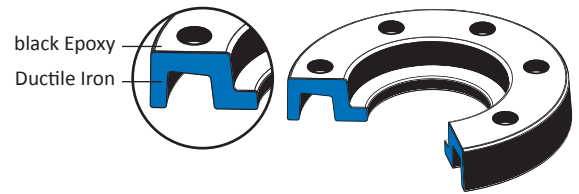

DA	DN	Code	Outside Dia. O.D.	Inside Dia. I.D.	Flange Thickness T	Bolt Circle B.C.	Bolt Hole B.D.	Bolt Count N	Bolt Size M	Radius r	Operating Pressure max. [bar]	Weight kg/pc.
50	40	DF2DI 50-10/16	150	62	16	110	18	4	M16	3	16	1,05
63	50	DF2DI 63-10/16	165	78	16	125	18	4	M16	3	16	1,30
75	65	DF2DI 75-10/16	185	92	16	145	18	4	M16	3	16	1,35
90	80	DF2DI 90-10/16	200	108	19	160	18	8	M16	3	16	1,75
110	100	DF2DI 110-10/16	220	128	19	180	18	8	M16	3	16	1,90
125	100	DF2DI 125-10/16	220	135	19	180	18	8	M16	3	16	1,80
140	125	DF2DI 140-10/16	250	158	19	210	18	8	M16	3	16	2,30
160	150	DF2DI 160-10/16	285	178	19	240	22	8	M20	3	16	2,95
180	150	DF2DI 180-10/16	285	188	19	240	22	8	M20	3	16	2,80
200	200	DF2DI 200-16	340	235	23	295	22	12	M20	4	16	4,30
225	200	DF2DI 225-16	340	238	23	295	22	12	M20	3	16	4,10
250	250	DF2DI 250-16	405	288	29	355	26	12	M24	3	16	6,60
280	250	DF2DI 280-16	405	294	29	355	26	12	M24	3	16	5,80
315	300	DF2DI 315-16	460	338	34	410	26	12	M24	3	16	8,50
355	350	DF2DI 355-16	520	376	39	470	26	16	M24	4	16	15,0
400	400	DF2DI 400-16	580	430	43	525	30	16	M27	4	16	18,6
450	500	DF2DI 450-16	715	517	46	650	33	20	M30	6,5	16	31,5
500	500	DF2DI 500-16	715	533	46	650	33	20	M30	7	16	29,8
560	600	DF2DI 560-16	840	618	55	770	36	20	M33	6	16	51,6
630	600	DF2DI 630-16	840	645	55	770	36	20	M33	6	16	49,0